



# Acoustic Pods 2.0

THE WINTECH COLLECTION





# EXTENDABLE DESKTOP



## PEACE IN A POD...

Choose wisely and outsmart your competitors to achieve better results.

Our pods now come with new amazing features, offering the most advantageous combination of cost, quality and sustainability to improve satisfaction and work performance.

The pods pairs finely crafted aesthetics with sustainable materials to protect our mother earth. Its sound insulation effects have been tested by international certification organisation, reflecting GO's ingenuity and our endeavour in creating a workspace that improves productivity and privacy.



# EXCELLENT AESTHETIC DESIGNS

**Air Purifying System with HEPA Filter.** The pod is well ventilated with filtered air to provide a comfortable and clean workspace to the user. **NEW**

**Motion Sensor for Energy Saving.** LED lighting and air ventilation system are activated by the motion sensor, and will be automatically turned off after 5 minutes of inactivity.

**Ergonomic and Exclusive Charging Ports.** CE certified charging ports with AC outlet, type A / type C 45W PD and CAT6 port. Input 110-240 VAC, 10A, 50-60Hz. **NEW**



**Acoustic Material for Sound Insulation.** The speech level reduction in the pod offers private and quiet environment, to be free from disturbances.

**Auto Close Tempered Glass Door.** The door can only be opened up to 95° to prevent collision against surroundings. **NEW**

**Elegant Door Handle.** Trendy and aesthetic designs making the pods an elegant component to the surroundings. **NEW**

**Knockout Hole for Sprinkler.** Sprinkler head can be installed based on safety requirement.

**Castors for The Ease of Mobility.** An add-on feature for PODS. \*Optional **NEW**

**Quick And Easy To Assemble.** Improved design which makes installation time possible within 30 minutes.



ELEGANT DOOR HANDLE

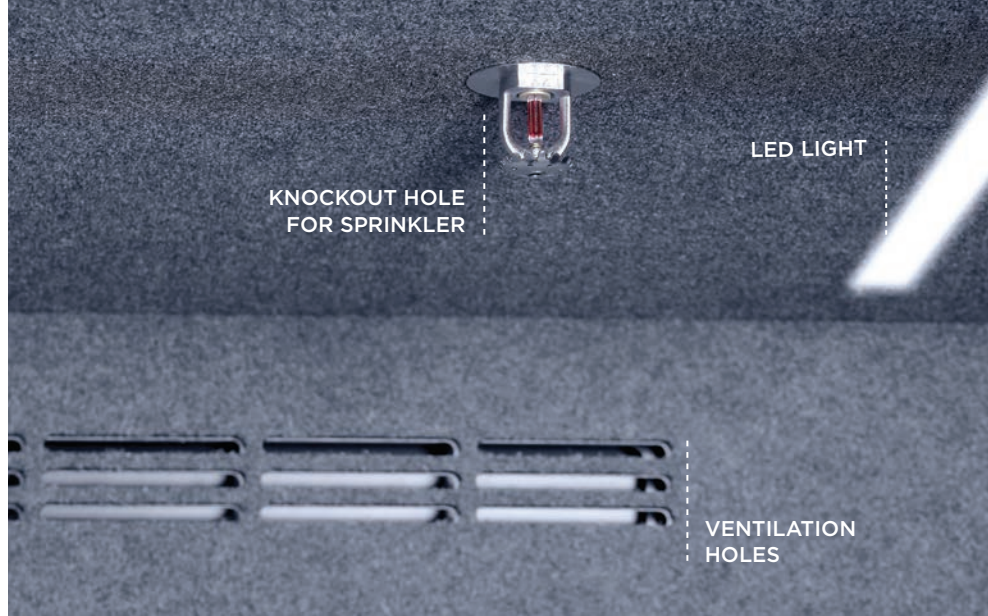

KNOCKOUT HOLE FOR SPRINKLER

LED LIGHT

VENTILATION HOLES



DIMMER

PD 45W



TYPE A / TYPE C



AC OUTLET



ENERGY EFFICIENT



**DESIGNED  
WITH  
INGENUITY**







# HIGH ACOUSTIC RATING





# RECYCLABLE & SUSTAINABLE

## Acoustic Material: Crafted To Perfection

Pods adopt 100 percent polyester, non-poisonous, harmless, non-irritant, and odourless acoustic material which offers excellent sound absorption. Most importantly, the acoustic materials are harmless to the environment because they can be recycled and reused.

The sound absorption alongside the quality, recyclability and reusability of the acoustic material have also been tested by the relevant testing boards. Our pods aim to put sustainability and societal impact at the heart of all its endeavours.



OEKO-TEX®  
CONFIDENCE IN TEXTILES  
STANDARD 100



## Prioritising “Green” Manufacturing Materials

We strive to create green, resilient and competitive products. Taking the manufacturing materials of SOLO POD 2.0 as an example, galvanized steel makes up 78 percent of the materials used. This can reduce the environmental burden to the planet earth and is in line with the ideal of sustainable development.

### SOLO POD 2.0

- Acoustic Material
- Aluminium
- Glass
- Wood
- Others
- Electro Galvanised Steel

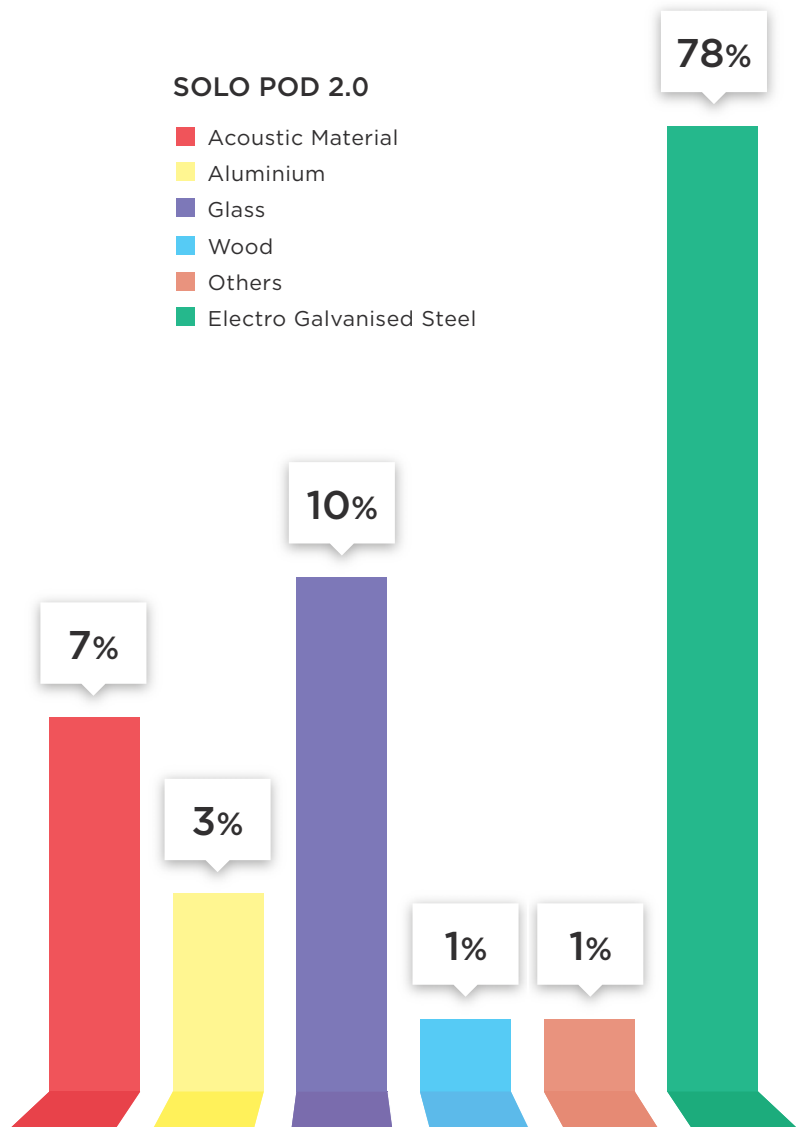



# PEACE WITH SOUND INSULATION

## We Care For Your Well-Being

In an environment with sound level is above 70 dB, you will soon find yourself difficult to remain focused and productive at work.

GO 2.0 pods have gone through rigorous test based on ISO 23351-1 standards, with the speech level reduction at 28.3 dB. It creates a serene and relaxing environment that counters the stress and anxiety of our daily grinds. GO 2.0 not only provides more opportunities for creative collaboration, but also helps to maximize users' concentration and satisfaction, as well as enjoy the quiet moment.

Aside from sound insulation, GO 2.0 has achieved GREENGUARD Certification which is scientifically proven to meet some of the world's most rigorous third-party chemical emissions standards, helping to reduce indoor air pollution and the risk of chemical exposure. The certification can contribute to LEED credits as well.

Certified by



**HIGH ACOUSTIC RATING**

**D<sub>s,A</sub> - 28.3 dB**

Based on ISO 23351-1 standard



**UL GREENGUARD  
CERTIFIED**



**HIGHEST  
QUALITY**





# COMFORTABLE AND BREATHABLE





# CLEAN AIR\* IN 2.0 PODS

GO 2.0 pods utilizes a top-notch air ventilation and air purifying technology to provide consumers a pleasant breathing environment.

The air ventilation system enables a high enough air exchange rate within the pod to provide a comfortable and healthy working environment.

Additionally, the included HEPA filter captures airborne particles to cleanse entering air and enhance air quality. It inadvertently lessens allergic responses.

The filtered air was tested based on ISO 14644-1:2015 standard.

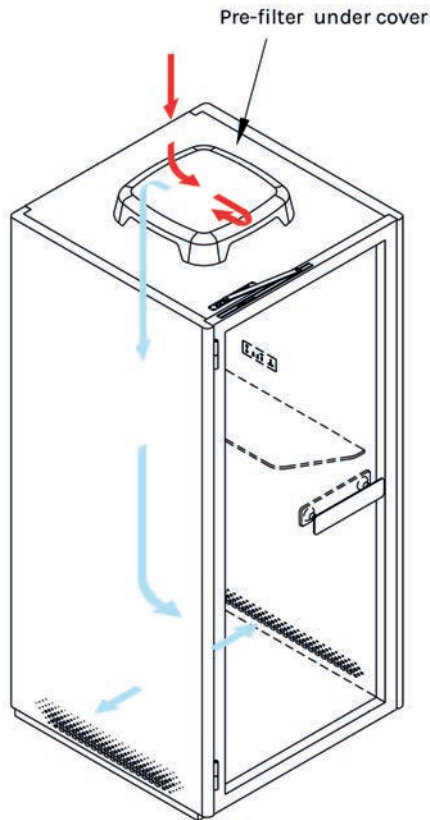

Model	Airflow (m <sup>3</sup> /h)	Air Change Per Hour (ACH)
SOLO 2.0	131	81
FOCUS 2.0	131	37
CONNECT 2.0	262	59
RETREAT 2.0	393	43

\*Air cleanliness by particle concentration

# 2.0 PODS

Acoustic Pod has now emerged to become a popular office furnishing product in the global market. GO 2.0 pods offer a new experience for workspace. A Serene, comfortable and practical solution to improve work efficiency. Comes in four models to suit the needs of different users.



## SOLO 2.0

SOLO POD 2.0 is a classic pod for single person. In the serene space, an individual can carry out works that require high level of privacy such as signing contracts, making phone calls, and video conference.

\* High stool not included.



## FOCUS 2.0

FOCUS POD 2.0 has a unique extendable desktop with multiple functions. This ergonomic feature allows you to adjust your working position, while providing a storage space. This spacious pod is suitable for individual who wants to work over a long period of time.



## CONNECT 2.0

CONNECT POD 2.0 can accommodate two to four persons.

The sofas come with comfortable backrest allow users to carry out discussions in a relaxed manner, most importantly free from disturbance. Aiming to achieve satisfaction and better results.



## RETREAT 2.0

RETREAT POD 2.0 is designed to fit up to five people, ideally for meeting, entertainment or relaxing.

Choice of L shaped sofa for a more casual setting or empty to create a more specific layout.

\* Side table and TV not included



# QUICK AND EASY TO ASSEMBLE

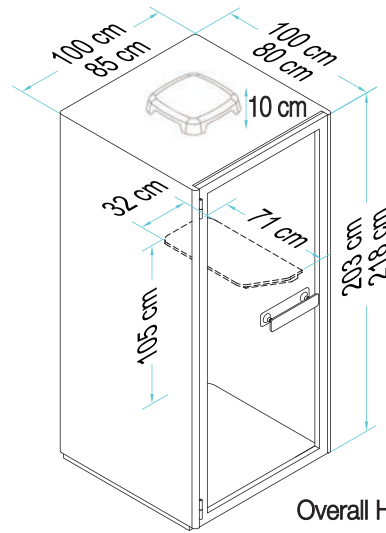

Overall Height: 228cm

## SOLO 2.0

1. Laminated desktop
2. Castors \*Optional
3. Power consumption: 0.18 A
4. Net weight: 278 kg

## FOCUS 2.0

1. Extendable desktop with storage space
2. Exclusive design of sofa with backrest
3. Castors \*Optional
4. Power consumption: 0.18 A
5. Net weight: 405 kg

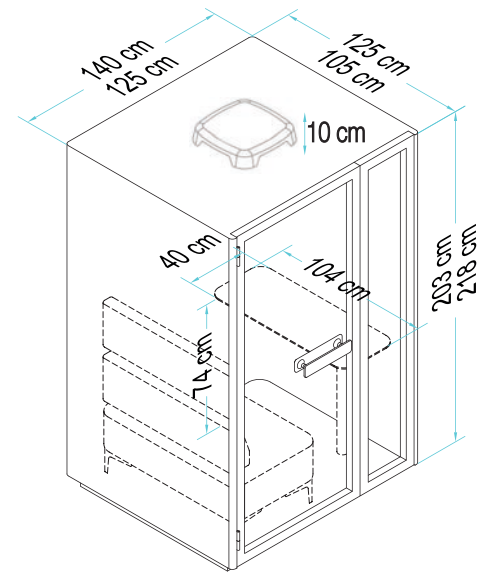

Overall Height: 228cm



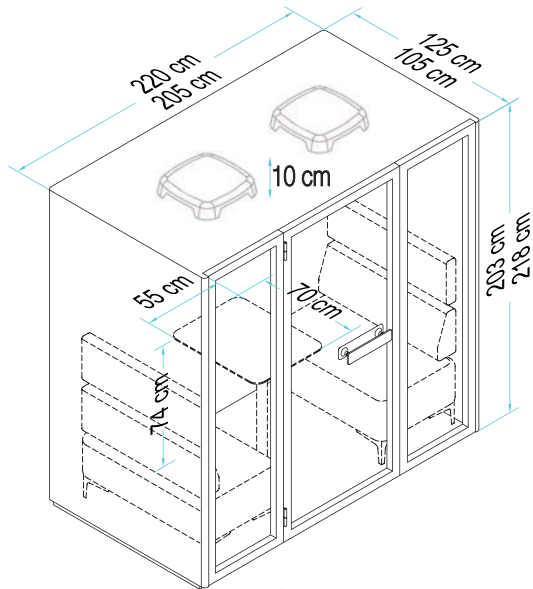

Overall Height: 228cm

## CONNECT 2.0

1. Laminated desktop
2. Exclusive design of sofa with backrest
3. Castors \*Optional
4. Power consumption: 0.33 A
5. Net weight: 532 kg

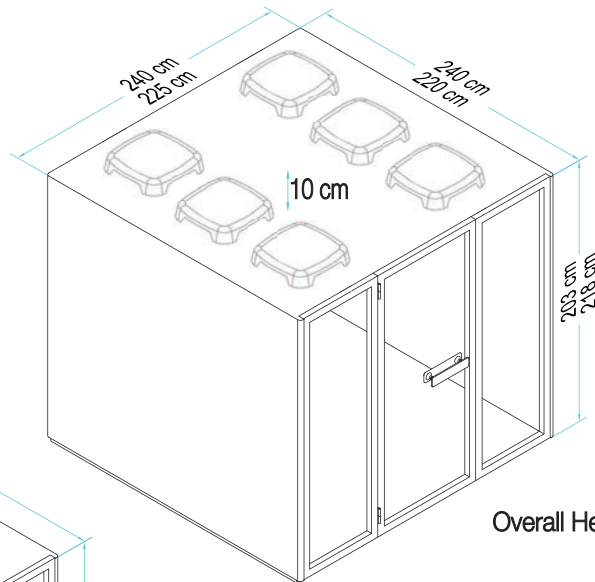

Overall Height: 228cm

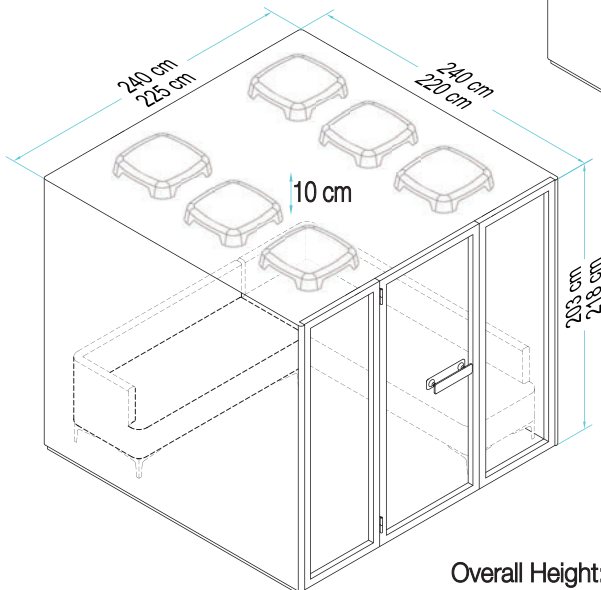

Overall Height: 228cm

## RETREAT 2.0

1. Selections of furnishing:
  - Exclusive L-shaped sofa
2. TV bracket with AC power socket \*Optional
3. Power consumption: 0.47 A
4. Net weight: 893 kg



# EXTERIOR

## COLOUR SELECTION



Space Grey

# INTERIOR

## ACOUSTIC SHEET COLOUR SELECTION

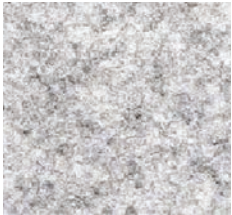

Light Grey



Charcoal Black

---

## CARPET COLOUR SELECTION



Black



Grey Flex (Retreat ONLY)

# SOFA

## FABRIC COLOUR SELECTION



1006 Dark Grey



1007 Grey

\*Display colours may slightly vary from the actual colours.





THE WINTECH COLLECTION

## CONTACT

---



### ADDRESS

Unit 1a  
Broomhill Business Complex  
Broomhill Road  
Dublin 24



### PHONE

0800 195 9030



### ONLINE

Email [sales@gooffice.co.uk](mailto:sales@gooffice.co.uk)

---

[gooffice.co.uk](http://gooffice.co.uk)



PLEASE SCAN

